

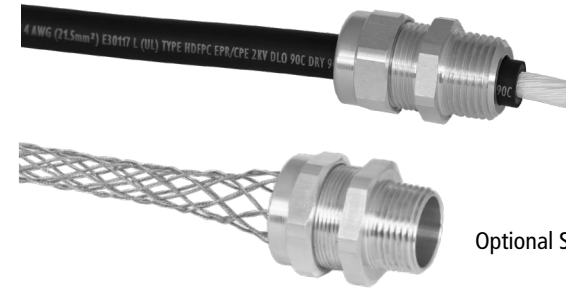

INSTALLATION INSTRUCTIONS FOR CMP 'CG' CORD GRIP CABLE GLAND

FOR TERMINATION OF FLEXIBLE CORD



Optional Strain relief device

Cable Gland Size	ORDER REFERENCE (NPT)	ENTRY THREAD	MINIMUM THREAD LENGTH	CABLE RANGE		ACROSS FLATS	ACROSS CORNERS	NOMINAL ASSEMBLY LENGTH
				MIN	MAX	MAX	MAX	
20S	CG-0375X046	3/8"	0.41	0.303	0.457	0.94	1.04	1.15
	CG-050X046	1/2"	0.53			0.94	1.04	1.15
	CG-075X046	3/4"	0.55			1.18	1.30	1.15
	CG-100X046	1"	0.68			1.48	1.63	1.22
	CG-125X046	1 1/4"	0.71			1.97	2.17	1.22
	CG-150X046	1 1/2"	0.72			2.17	2.38	1.30
	CG-200X046	2"	0.76			2.56	2.81	1.30
20	CG-050X054	1/2"	0.53	0.303	0.539	1.18	1.30	1.13
	CG-075X054	3/4"	0.55			1.18	1.30	1.17
	CG-100X054	1"	0.68			1.48	1.63	1.20
	CG-125X054	1 1/4"	0.71			1.97	2.17	1.20
	CG-150X054	1 1/2"	0.72			2.17	2.38	1.28
	CG-200X054	2"	0.76			2.56	2.81	1.28
	CG-075X080	3/4"	0.55			1.48	1.63	1.47
25	CG-100X080	1"	0.68	0.512	0.799	1.48	1.63	1.51
	CG-125X080	1 1/4"	0.71			1.97	2.17	1.51
	CG-150X080	1 1/2"	0.72			2.17	2.38	1.59
	CG-200X080	2"	0.76			2.56	2.81	1.59
	CG-100X104	1"	0.68			1.73	1.91	1.42
	CG-125X104	1 1/4"	0.71			1.97	2.17	1.42
	CG-150X104	1 1/2"	0.72			2.17	2.38	1.50
32	CG-200X104	2"	0.76	0.752	1.043	2.56	2.81	1.50
	CG-125X128	1 1/4"	0.71			2.17	2.38	1.45
	CG-150X128	1 1/2"	0.72			2.17	2.38	1.53
	CG-200X128	2"	0.76			2.56	2.81	1.53
	CG-150X149	1 1/2"	0.72			2.36	2.60	1.56
	CG-200X149	2"	0.76			2.56	2.81	1.56
	CG-200X174	2"	0.76			1.433	1.744	2.56

Dimensions are displayed in inches unless otherwise stated

NOTE: For material options replace 'X' in order reference with the following codes, Brass 'B', Nickel Plated Brass 'NB', Aluminum 'A', Mild Steel 'MS', and Stainless Steel 'SS'.
Examples - CG-050A046 = 1/2" NPT Aluminum, CG-100MS104 = 1" NPT Mild Steel

F1611		
Revision Reason	Revision Number	Revision Date
IFS	2	10/20
cJLus	2	10/20



Glasshouse Street • St. Peters • Newcastle upon Tyne • NE6 1BS
Tel: +44 191 265 7411 • Fax: +44 1670 715 646
E-Mail: customerservices@cmp-products.com • Web: www.cmp-products.com

TECHNICAL DATA

CABLE GLAND TYPE : 'CG' CORD GRIP
INGRESS PROTECTION : IP66, 67, 68
TYPE RATING : NEMA 4X, 6P
PROCESS CONTROL SYSTEM : ISO 9001
: ISO/IEC 80079-34:2011

EXPLOSIVE ATMOSPHERES CLASSIFICATION

UL CERTIFICATE NUMBER : E509101
CODE OF PROTECTION : Class III, Div 2; Enclosure type 4X, 6P

Cord Grip cable glands can be used in Classified Locations when installed per the requirements of the NEC and CEC

INSTALLATION INSTRUCTIONS

Installation should only be performed by a competent person using the correct tools. Spanners should be used for tightening. Read all instructions before beginning installation.

INSTALLATION GUIDANCE NOTES

- In accordance with NEC & CEC requirements, cable glands with NPT entry threads are suitable for both divisions and zones.
- The interface between a cable entry device and its associated enclosure/cable entry will require additional sealing to achieve ingress protection (IP) ratings higher than IP54. The minimum protection level is IP54 for explosive gas atmospheres and IP6X for explosive dust atmospheres. Parallel threads (and tapered threads when using a non-threaded entry) require a CMP sealing washer to maintain IP66, 67 and 68 (when applicable). It is the installer's responsibility to ensure the IP rating is maintained at the interface.
Note: When fitted to a threaded entry, NPT threads on this product will automatically provide an ingress protection rating of IP68 but the addition of non-setting, non-metallic thread grease is good installation practice on taper threaded entries. Cord Grip cable glands are supplied with a thread seal to provide NEMA 4X, 6P and IP68 ratings.
- The interface between a cable entry device and its associated enclosure/cable entry will require additional sealing to achieve Type ratings higher than 3, 3X, 3S, 3SX, 3R & 3RX. Parallel threads (and tapered threads when using a non-threaded entry) require a CMP sealing washer to maintain 4X & 6P protection. It is the installer's responsibility to ensure the Type rating is maintained at the interface.
Note: When fitted to a threaded entry, NPT threads on this product will automatically provide an ingress protection rating of IP68 but the addition of non-setting, non-metallic thread grease is good installation practice on taper threaded entries. Cord Grip cable glands are supplied with a thread seal to provide NEMA 4X, 6P and IP68 ratings.
NPT threads are in accordance with ASME B1.20.1-2013 gauging to CI 3.2 for external threads.
Enclosures must be strong enough to support the cable and cable gland assembly. The enclosure surface finish must be smooth and flat to facilitate sealing with an Entry Thread Sealing Washer for the required IP rating.
- Enclosure walls must be sufficiently strong enough to support the cable and cable gland assembly. Enclosure entries shall be perpendicular. Any draft angles from the casting/moulding process should have a perpendicular flat spot machined to facilitate sealing with an entry thread sealing washer.
- CMP Products recommends that when using the cable gland with a clearance hole, the clearance hole must be circular, free of burrs and the diameter no larger than the maximum diameter of the conduit opening as detailed in UL514B, Table 14. A suitable CMP Products locknut shall be used to secure the product. See CMP Products catalogue for locknut options.
- Cable glands do not have any serviceable parts and are therefore not intended to be repaired.

SPECIAL CONDITIONS FOR SAFE USE

- Cable gland size 20S (0375) when supplied with a 3/8" NPT entry thread is classified as a component and will be marked as such.

Number of turns to tighten	GLAND SIZE							Cable Diameter (inches)
	20S	20	25	32	40	50S	50	
1.5				1.043				
2				1.008		1.492	1.744	
2.25			0.799	0.988		1.472	1.724	
2.5	0.457		0.776	0.972	1.280	1.457	1.701	
3	0.429	0.539	0.724	0.937	1.205	1.417	1.657	
3.5	0.398	0.480	0.669	0.898	1.130	1.378	1.614	
4	0.366	0.421	0.618	0.862	1.055	1.339	1.567	
4.5	0.335	0.362	0.567	0.827	0.980	1.299	1.524	
5	0.303	0.303	0.512	0.791	0.906	1.260	1.480	
5.5				0.752		1.220	1.433	

J. Hichens

Jonathan Hichens - Lead Certification Engineer - (Authorised Person)
CMP Products Limited, Cramlington, NE23 1WH, UK
7th October 2020

INSTALLATION INSTRUCTIONS FOR CMP CORD GRIP CABLE GLAND

CABLE GLAND COMPONENTS

1. Entry component
2. Seal
3. Skid washer
4. Plunging skid washer
5. Outer seal nut
6. Conduit locknut
7. Entry thread seal
8. Optional strain relief device

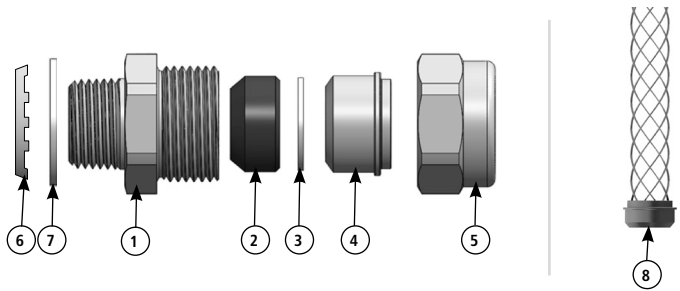

PLEASE READ ALL INSTRUCTIONS CAREFULLY BEFORE BEGINNING THE INSTALLATION

If using strain relief device: Remove the outer seal nut (5) and replace the plunging skid washer (4) with optional strain relief device (8). Pass outer seal nut over mesh and hand tighten onto the entry component.

If not using the strain relief device: It is not necessary to disassemble the gland.

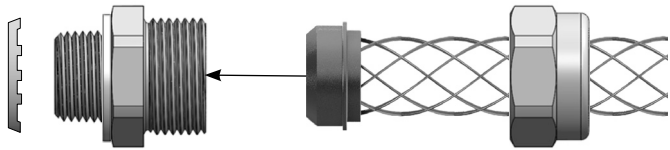

The following steps remain the same if you have the strain relief device fitted.

1. Secure the gland into the equipment and fully tighten the conduit locknut (6).

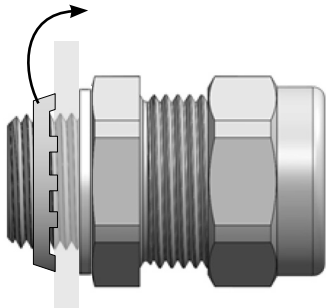

2. Determine the conductor length to suit the geometry of the equipment and prepare the cable accordingly, removing part of the outer sheath where required to reveal the insulated conductors.



3. Slacken the outer seal nut (5) to relax the seal (2).

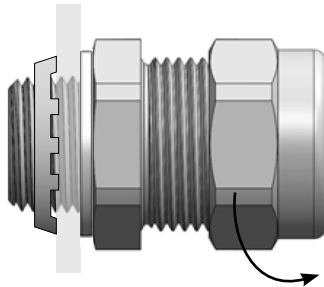

4. Pass the cable through the gland to the desired position, then tighten the outer seal nut (5) by hand until resistance is felt.

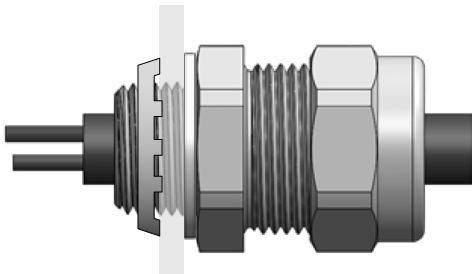

5. Tighten the outer seal nut the number of turns outlined in the table shown overleaf.

