



TECHNICAL DATA

CABLE GLAND TYPE : C2KX
 INGRESS PROTECTION : IP66, IP67, IP68, NEMA 4X
 PROCESS CONTROL SYSTEM : ISO 9001
 : ISO/IEC 80079-34:2011

EXPLOSIVE ATMOSPHERES CLASSIFICATION

ATEX CERTIFICATION No : CML 18ATEX1323X, CML 18ATEX4315X
 ATEX CERTIFICATION CODE : II 2G, II 1D, Ex eb IIC Gb, Ex ta IIIC Da
 UKEX CERTIFICATION No : CML 21UKEX1251X
 UKEX CERTIFICATION CODE : II 2G, II 1D, Ex eb IIC Gb, Ex ta IIIC Da
 IECEx CERTIFICATION No : IECEx CML 18.0180X
 IECEx CERTIFICATION CODE : Ex eb IIC Gb, Ex ta IIIC Da
 CSA CERTIFICATION No : 2367109
 CSA CERTIFICATION CODE : Class I, Zone 1, AEx e II, AEx nR II
 UL CERTIFICATION No : E200163, E256367
 UL CERTIFICATION CODE : Class I, Zone 1, AEx e II

INSTALLATION INSTRUCTIONS

- Installation should only be performed by a competent person using the correct tools. Read all instructions before beginning installation.
- The interface between a cable entry device and its associated enclosure / cable entry will require additional sealing to achieve ingress protection (IP) ratings higher than IP54. The minimum protection level is IP54 for explosive gas atmospheres and IP6X for explosive dust atmospheres. Parallel threads (and tapered threads when using a non-threaded entry) require a CMP sealing washer or integral O-ring face seal (where available) to maintain IP66, 67 and 68 (when applicable). It is the installer's responsibility to ensure the IP rating is maintained at the interface.
 Note: When fitted to a threaded entry, all tapered threads will automatically provide an ingress protection rating of IP66.
- A CMP earth tag should be used when it is necessary to provide an earth bond connection. CMP earth tags have been independently tested to comply with Category B rating specified in IEC 62444 (there are no ratings stated in IEC 60079-0). Ratings are shown in the associated table. CMP earth tags slip over the cable gland or access-ry entry thread from inside/outside the enclosure and must be secured with a locknut (if fitted internally).
- Metric entry threads comply with ISO 965-1 and ISO 965-3 with a 6g tolerance as required by IEC 60079-1:2014. The CMP standard metric thread pitch is 1.5mm for threads up to M75, and 2.0mm from M90 and above. Special thread pitches between 0.7 – 2.0mm are available on all products on request. See certificate for details of other thread types. NPT threads are in accordance with ASME B1.20.1-2013 gauging to CI 3.2 for external threads. For details of other thread types refer to IECEx certificate.
- Enclosures must be strong enough to support the cable and cable gland assembly. The enclosure surface finish must be smooth and flat to facilitate sealing with an O-ring or Entry Thread Sealing Washer for the required IP rating.
- Enclosure walls must be sufficiently strong enough to support the cable and cable gland assembly. Enclosure entries shall be perpendicular. Any draft angles from the casting/moulding process should have a perpendicular flat spot machined to facilitate sealing with an O-ring or Entry Thread Sealing Washer.
- CMP Products recommends that when using the cable gland with a through-hole, the hole must be circular, free of burrs and the diameter no larger than 0.7mm above the thread major diameter. A suitable CMP Products locknut shall be used to secure the product. See CMP Products catalogue for locknut options
- Cable glands do not have any serviceable parts and are therefore not intended to be repaired.



INSTALLATION INSTRUCTIONS FOR CMP CABLE GLAND TYPES C2KX

FOR TERMINATION OF CABLES WITH WIRE BRAID IN HAZARDOUS LOCATIONS.

INCORPORATING EU DECLARATION OF CONFORMITY TO DIRECTIVE 2014/34/EU AND UK STATUTORY REQUIREMENTS SI 2016 No. 1107 (AS AMENDED)

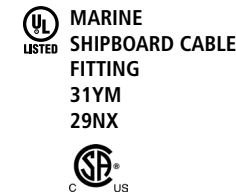

| CMP Earth Tag Size | Short Circuit Ratings Symmetrical Fault Current (kA) for 1 second |
|--------------------|---|
| 20 | 3.06 |
| 25 | 4.06 |
| 32 | 5.40 |
| 40 | 7.20 |
| 50 | 10.40 |
| 63 | 10.40 |
| 75 | 10.40 |

| Outer Seal Tightening Guide | | GLAND SIZE | | | | | | | | | | | | |
|-----------------------------|----------------|------------|------|------|------|------|------|------|------|------|------|------|------|--|
| Number of turns to tighten | CABLE DIAMETER | | | | | | | | | | | | | |
| | 20S16 | 20S | 20 | 25S | 25 | 32 | 40 | 50S | 50 | 63S | 63 | 75S | 75 | |
| 0.5 | 13.2 | 15.9 | 20.9 | 22.0 | 26.2 | 33.9 | | | | | | | | |
| 1 | 12.5 | 15.3 | 20.0 | 21.2 | 25.4 | 32.9 | 40.4 | 46.7 | 52.8 | 59.2 | 65.9 | 72.1 | 78.5 | |
| 1.5 | 11.9 | 14.7 | 19.0 | 20.4 | 24.6 | 31.9 | 39.0 | 45.4 | 51.4 | 57.7 | 64.6 | 70.6 | 77.2 | |
| 2 | 11.2 | 14.2 | 18.1 | 19.6 | 23.8 | 30.8 | 37.6 | 44.1 | 50.0 | 56.2 | 63.4 | 69.2 | 75.9 | |
| 2.5 | 10.5 | 13.6 | 17.2 | 18.8 | 23.0 | 29.8 | 36.2 | 42.9 | 48.7 | 54.7 | 62.1 | 67.7 | 74.6 | |
| 3 | 9.8 | 13.0 | 16.2 | 18.0 | 22.2 | 28.8 | 34.8 | 41.6 | 47.3 | 53.2 | 60.9 | 66.3 | 73.3 | |
| 3.5 | 9.2 | 12.4 | 15.3 | 17.2 | 21.4 | 27.8 | 33.5 | 40.3 | 45.9 | 51.6 | 59.6 | 64.8 | 71.9 | |
| 4 | 8.5 | 11.8 | 14.4 | 16.4 | 20.6 | 26.8 | 32.1 | 39.0 | 44.5 | 50.1 | 58.4 | 63.4 | 70.6 | |
| 4.5 | 7.8 | 11.2 | 13.4 | 15.6 | 19.8 | 25.7 | 30.7 | 37.8 | 43.2 | 48.6 | 57.1 | 61.9 | 69.3 | |
| 5 | 7.1 | 10.7 | 12.5 | 14.8 | 19.0 | 24.7 | 29.3 | 36.5 | 41.8 | 47.1 | 55.9 | 60.5 | 68.0 | |
| 5.5 | 6.5 | 10.1 | 12.0 | 14.0 | 18.2 | 23.7 | 27.9 | 35.2 | 40.4 | 45.6 | 54.6 | 59.0 | 66.7 | |
| 6 | 5.8 | 9.5 | | | | | | | | | | | | |

SPECIAL CONDITIONS FOR SAFE USE

For ATEX & IECEx certification:

- C2KX cable glands are only suitable for fixed installations. Cables must be effectively clamped to prevent twisting and pulling

For American Ex certification:

- C2KX cable glands are only suitable for fixed installations. Cables must be effectively clamped to prevent twisting and pulling.
- According to C.E.C. and the N.E.C. wiring method for the types of cables that can be used in Class I, Zone 1 and 2 Classified Areas, according to 60079-14 installation wiring method restrictions.
- Shipboard Cables are for use on Marine Platform and/or shipboards only and are subject to local authorities having jurisdiction on the installation.
- Sizes 25S and 100 are not covered by UL and CSA certification.

ACCESSORIES

The following accessories are available from CMP Products, as optional extras, to assist with fixing, sealing and earthing :

- Locknut, Earth Tag, Serrated Washer, Entry Thread (I.P.) Sealing Washer, Shroud

CMP Products Limited on its sole responsibility declares that the equipment referred to herein conforms to the requirements of the ATEX Directive 2014/34/EU and UK statutory requirements SI 2016 No. 1107 (as amended). This is shown in the following harmonised/designated standards;

EN 60079-0:2018, EN 60079-7:2015 + A1:2018, EN 60079-15:2017, EN 60079-31:2014, BS 6121:1989, EN 62444:2013

Malcolm Webber - Product Engineering Manager - (Authorised Person)
 CMP Products Limited, Cramlington, NE23 1WH, UK

EU Economic Operator: CMP Products Germany GmbH. Address: Lukasstraße 25a, 52070 Aachen 17th March 2020



Notified Body: CML B.V., Koopvaardijweg 32, 4906CV Oosterhout, The Netherlands

Approved Body: Eurofins E&E CML Limited, Newport Business Park, New Port Road, Ellesmere Port, CH65 4LZ

Cable Gland Selection Table

| Cable Gland Size | Available Entry Threads (Alternate Metric Thread Lengths Available) | | Minimum Thread Length | | Cable Bedding Diameter | Overall Cable Diameter | | | Armour Range † Grooved Cone (X) | | Across Flats | Across Corners | Protrusion Length | Ordering Reference (*Nickel Plated Brass NPT) | | | Shroud | Cable Gland Weight (Ozs) | | |
|------------------|---|--------|-----------------------|--------|------------------------|------------------------|-------|-------|---------------------------------|-------|--------------|----------------|-------------------|---|------|---------|--------|--------------------------|------|-----------------|
| | Standard | Option | NPT | Metric | | Max | Min | Max | Min | Max | | | | Max | Max | Size | | | Type | Ordering Suffix |
| | | | | | | | | | | | | | | | | | | | | |
| 20s16 | 1/2" | 3/4" | M20 | 0.78 | 0.59 | 0.343 | 0.240 | 0.516 | 0.012 | 0.040 | 1.201 | 1.321 | 2.559 | 20S16 | C2KX | 1RA531 | PVC06 | 8.187 | | |
| 20S | 1/2" | 3/4" | M20 | 0.78 | 0.59 | 0.461 | 0.374 | 0.626 | 0.012 | 0.040 | 1.201 | 1.321 | 2.441 | 20S | C2KX | 1RA531 | PVC06 | 7.960 | | |
| 20 | 1/2" | 3/4" | M20 | 0.78 | 0.59 | 0.551 | 0.492 | 0.823 | 0.016 | 0.040 | 1.201 | 1.321 | 2.480 | 20 | C2KX | 1RA531 | PVC06 | 7.860 | | |
| 25S | 3/4" | 1" | M25 | 0.80 | 0.59 | 0.787 | 0.551 | 0.866 | 0.016 | 0.048 | 1.476 | 1.624 | 2.736 | 25S | C2KX | 1RA532 | PVC09 | 12.240 | | |
| 25 | 3/4" | 1" | M25 | 0.80 | 0.59 | 0.787 | 0.717 | 1.031 | 0.016 | 0.048 | 1.476 | 1.624 | 2.736 | 25 | C2KX | 1RA532 | PVC09 | 12.240 | | |
| 32 | 1" | 1 1/4" | M32 | 0.98 | 0.59 | 1.024 | 0.933 | 1.335 | 0.016 | 0.048 | 1.811 | 1.992 | 2.953 | 32 | C2KX | 1RA533 | PVC11 | 19.471 | | |
| 40 | 1 1/4" | 1 1/2" | M40 | 1.01 | 0.59 | 1.268 | 1.098 | 1.591 | 0.016 | 0.062 | 2.165 | 2.382 | 2.953 | 40 | C2KX | 1RA534 | PVC15 | 26.455 | | |
| 50S | 1 1/2" | 2" | M50 | 1.03 | 0.59 | 1.504 | 1.386 | 1.839 | 0.016 | 0.062 | 2.362 | 2.598 | 3.031 | 50S | C2KX | 1RA535 | PVC18 | 30.265 | | |
| 50 | 2" | 2 1/2" | M50 | 1.06 | 0.59 | 1.736 | 1.591 | 2.087 | 0.024 | 0.062 | 2.760 | 3.036 | 3.031 | 50 | C2KX | 1RA536 | PVC21 | 40.001 | | |
| 63S | 2" | 2 1/2" | M63 | 1.06 | 0.59 | 1.969 | 1.795 | 2.339 | 0.024 | 0.062 | 2.953 | 3.248 | 3.150 | 63S | C2KX | 1RA536 | PVC23 | 46.773 | | |
| 63 | 2 1/2" | 3" | M63 | 1.57 | 0.59 | 2.205 | 2.150 | 2.591 | 0.024 | 0.062 | 3.150 | 3.465 | 3.150 | 63 | C2KX | 1RA537 | PVC25 | 47.373 | | |
| 75S | 2 1/2" | 3" | M75 | 1.57 | 0.59 | 2.441 | 2.323 | 2.835 | 0.024 | 0.062 | 3.543 | 3.898 | 3.426 | 75S | C2KX | 1RA537 | PVC28 | 71.394 | | |
| 75 | 3" | 3 1/2" | M75 | 1.63 | 0.59 | 2.528 | 2.626 | 3.087 | 0.024 | 0.062 | 3.937 | 4.331 | 3.465 | 75 | C2KX | 1RA538 | PVC30 | 87.409 | | |
| 90 | 3 1/2" | 4" | M90 | 1.69 | 0.94 | 3.094 | 3.000 | 3.555 | 0.032 | 0.062 | 4.528 | 4.980 | 4.016 | 90 | C2KX | 1RA539 | PVC32 | 124.270 | | |
| 100 | 4" | 5" | M100 | 1.73 | 0.94 | 3.583 | 3.390 | 3.992 | 0.032 | 0.062 | 4.843 | 5.500 | 4.488 | 100 | C2KX | 1RA5310 | LSF33 | 101.131 | | |

† Dimensions are displayed in inches unless otherwise stated

| F1425 | | |
|---------------|----------|-------|
| Certification | Revision | Date |
| UKEX | 0 | 04/21 |
| IFS | 16 | 03/24 |
| ATEX / IECEx | 7 | 4/19 |
| CSA / CSAus | 7 | 12/18 |
| UL | 7 | 12/18 |



Glasshouse Street • St. Peters • Newcastle upon Tyne • NE6 1BS
 Tel: +44 191 265 7411 • Fax: +44 1670 715 646
 E-Mail: customerservices@cmp-products.co.uk • Web: www.cmp-products.com

INSTALLATION INSTRUCTIONS FOR CMP CABLE GLAND TYPES C2KX

CABLE GLAND COMPONENTS - It is not necessary to dismantle the cable gland any further than illustrated below

1. Entry Component
2. Detachable Armour Cone
3. AnyWay Clamping
4. Body
5. Outer Seal Nut

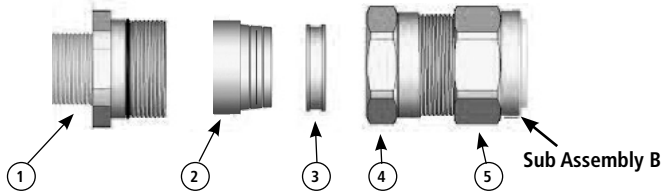

PLEASE READ ALL INSTRUCTIONS CAREFULLY BEFORE BEGINNING THE INSTALLATION

1. Slacken the Outer Seal Assembly (5), but do not remove it from the Body (4). Separate the gland components by removing the Body (4) and the Outer Seal Assembly (5) as one unit. (Note that the Armour Cone (2) and AnyWay Clamping Ring (3) are loose items). Pass the Body (4), Outer Seal Assembly (5) and AnyWay Clamping Ring (3) over the cable, Outer Seal Assembly (5) first.

2. Prepare the cable by stripping back the cable outer sheath and armour to suit the equipment geometry.

Expose the armour by stripping back the outer sheath further using the table below as a guide.

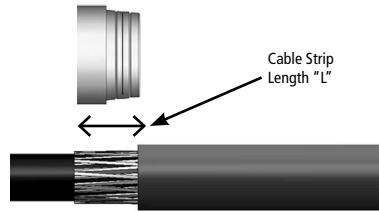

| CABLE GLAND SIZE | 20S/16, 20S, 20 | 25S, 25, 32, 40 | 50S, 50, 63S, 63 | 75S, 75, 90, 100, 115, 130 |
|------------------------|-------------------------|-------------------------|-------------------------|----------------------------|
| CABLE STRIP LENGTH "L" | 12 mm (0.472 inches) | 15 mm (0.591 inches) | 18 mm (0.709 inches) | 20 mm (0.787 inches) |

3. Secure the Entry Component (1) to the equipment by tightening with a spanner.

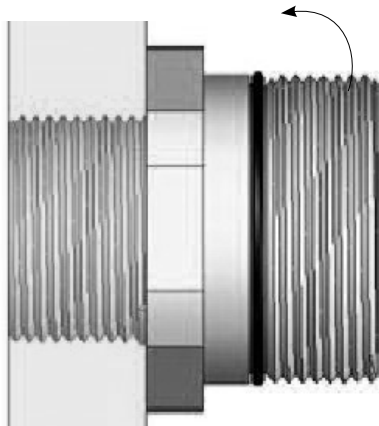

4. Locate the Armour Cone (2) in the Entry Component (1). Pass the cable through the Cone (2) and Entry Component (1), evenly spacing the braid armour around the Cone (2).

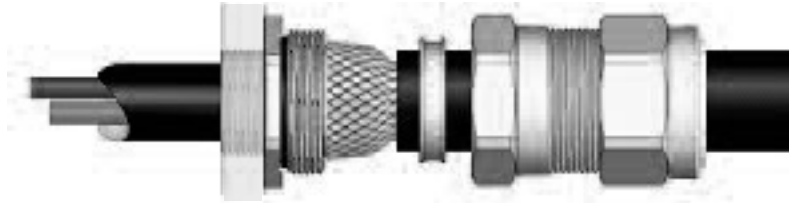

5. While continuing to gently push the cable forward to keep the braid or armour in contact with the Cone (2), tighten the Body (4) first by hand and then with a spanner until the Body (4) is fully tightened onto the Entry Component (1) and no threads are visible.

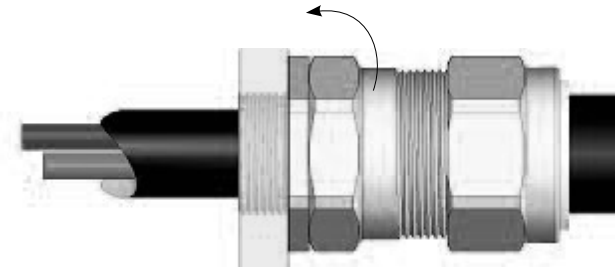

6. Only using finger pressure, tighten the outer seal nut assembly until light resistance to tightening is met.

Then either use the outer seal tightening guide tape or table on the rear of the page to determine how much further to tighten the seal using a spanner (using the outer seal tightening guide is recommended).

Wrap the outer seal tightening guide tape around the cable to show the amount of spanner turns needed (as shown here). Make sure the correct side of the outer seal tightening guide tape is used depending on the cable gland size.

